

RT MBP

Installation and user manual

Service and support:

Call your local service representative

SAFETY INSTRUCTIONS

SAVE THESE INSTRUCTIONS. This manual contains important instructions that should be followed during installation and maintenance of the PDU.

The PDU models that are covered in this manual are intended for installation in an environment within 0 to 50°C, free of conductive contaminant.

Certification standards

- Safety: EN 62040-1
- EMC: IEC/EN 62040-2
- Performance: IEC/EN 62040-3
- IEC 61000-4-2 (ESD): level 3.
- IEC 61000-4-3 (Radiated field): level 3.
- IEC 61000-4-4 (EFT): level 4.
- IEC 61000-4-5 (Fast transients): level 4.
- IEC 61000-4-6 (Electromagnetic field): level 3.
- IEC ©61000-4-8 (Conducted magnetic field): level 4.

Special symbols

The following are examples of symbols used on the PDU to alert you the important information:



RISK OF ELECTRIC SHOCK - Observe the warning associated with the risk of electric shock symbol.



Important instructions that must always be followed.



This symbol indicates that you should not discard waste electrical or electronic equipment (WEEE) in the trash. For proper disposal, contact your local recycling/reuse or hazardous waste center.



Information, advice, help.



Refer to the user manual.

Safety of persons

- Terminal blocks may be energized even if the system is disconnected from the AC power source.
- Dangerous voltage levels are present within the system. It should be opened exclusively by qualified service personnel.
- The system must be properly grounded, always connect the earth wire first.

Product safety

- The PDU connection instructions and operation described in the manual must be followed in the indicated order.
- CAUTION - To reduce the risk of fire, the unit connects only to a circuit provided with branch circuit overcurrent protection for :
63A rating, for 6kVA models,
100A rating, for 10kVA models
The upstream circuit breaker for Normal AC/Bypass AC must be easily accessible. The unit can be disconnected from AC power source by opening this circuit breaker.
- Disconnection and overcurrent protection devices shall be provided by others for permanently connected AC input (Normal AC/Bypass AC) and AC output circuits.
- Check that the indications on the rating label correspond with your AC powered system and the actual electrical consumption of all the equipment to be connected to the system.
- For PLUGGABLE EQUIPMENT, the socket-outlet shall be installed near the equipment and shall be easily accessible.
- Never install the system near liquids or in an excessively damp environment.
- Never let a foreign body penetrate inside the system.
- Never block the ventilation grates of the system.
- Never expose the system to direct sunlight or source of heat.
- If the system must be stored prior to installation, storage must be in a dry place.
- The admissible storage temperature range is -25°C to +60°C.

Special precautions

- This PDU is designed to work with UPS.
- All repairs and service should be performed by AUTHORIZED SERVICE PERSONNEL ONLY. There are NO USER SERVICEABLE PARTS inside the PDU.

Contents

1. Introduction	1
1.1 Environmental protection.....	1
2. Presentation.....	2
3. Installation	3
3.1 Inspecting the equipment	3
3.2 Unpacking the Unit.....	3
3.3 Checking the accessory kit.....	3
3.4 Install the PDU	4
4. AC Power cables connection	7
4.1 AC source to PDU.....	7
5. Service operation	8
5.1 How to switch PDU to BYPASS model	8
5.2 How to disconnect cables between PDU and UPS	8
5.3 How to switch PDU to NORMAL model	9
6. Specifications	10

1. Introduction

Thank you for selecting PDU to protect your electrical equipment.

This PDU allows service person to service or replace the UPS without interrupting the connected loads. Besides, it also allow you apply for below extension used:

- ◆ Terminal block connection design enable the PDU connect to other type UPS.
- ◆ Rotatable ‘rail kit’ design for easy service operation in a rack cabinet.
- ◆ Flexible position installation.

We recommend that you take the time to read this manual to take full advantage of the many features of your PDU.

1.1 Environmental protection

Products are developed according to an eco-design approach.

Substances

This product does not contain CFCs, HCFCs or asbestos.

Packing

To improve waste treatment and facilitate recycling, separate the various packing components.

- The cardboard we use comprises over 50% of recycled cardboard.
- Sacks and bags are made of polyethylene.
- Packing materials are recyclable and bear the appropriate identification symbol

Materials	Abbreviations	Number in the symbols	
Polyethylene terephthalat	PET	01	
High-density polyethylene	HDPE	02	
Polyvinyl chloride	PVC	03	
Low-density polyethylene	LDPE	04	
Polypropylene	PP	05	
Polystyrene	PS	06	

Follow all local regulations for the disposal of packing materials.

Product

The product is made up of recyclable materials.

Dismantling and destruction must take place in compliance with all local regulations concerning waste. At the end of its service life, the product must be transported to a processing center for electrical and electronic waste.

2. Presentation

Front view:

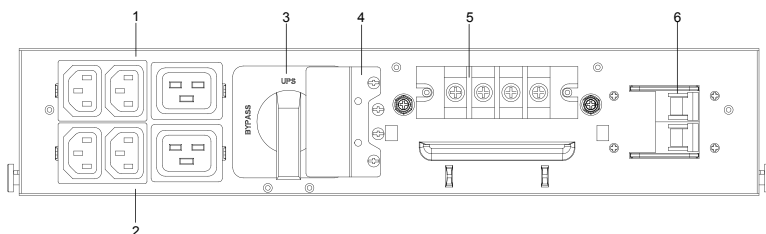

Rear view:

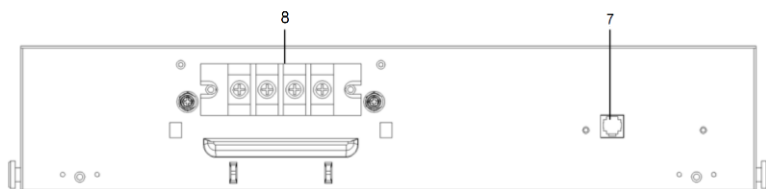

1. Output socket group 1 (Normal output)
2. Output socket group 2 (Programmable output)
3. Maintenance bypass switch
4. Maintenance switch cover
5. Input /Output terminal connected to power and load
(4pole IPL, IPN, OPL, OPN. PE is screw)
6. Input switch
7. RJ11 (connect to UPS, only for RT UPS)
8. Input /Output terminal connected to UPS
(4pole IPL, IPN, OPL, OPN. PE is screw)

3. Installation

The system may be installed only by qualified electricians in accordance with applicable safety regulations.

3.1 Inspecting the equipment

If any equipment has been damaged during shipment, keep the shipping cartons and packing materials for the carrier or place of purchase and file a claim for shipping damage. If you discover damage after acceptance, file a claim for concealed damage.

3.2 Unpacking the Unit



- Unpacking the unit in a low-temperature environment may cause condensation occurred in and on the cabinet. Do not install the unit until the inside and outside of the unit are absolutely dry (hazard of electric shock).

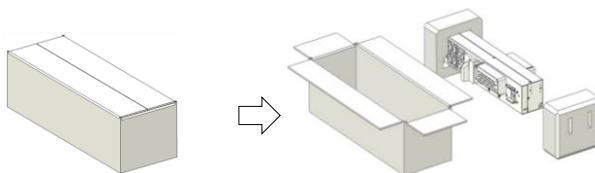

Note:

Discard or recycle the packaging in a responsible manner, or store it for future use.



Packing materials must be disposed in compliance with all local regulations concerning waste. Recycling symbols are printed on the packing materials to facilitate sorting.

3.3 Checking the accessory kit

Verify that the following additional items are included with the unit:

Cables for UPS's Input / Output(For 6K)	V	1 Set
Cables for UPS's Input / Output(For 10K)	V	1 Set
RJ11 cable	V	1 PC
Cable locker	V	2 PCS
Ear bracket(For tower installation)	V	2 PCS
Rail kit(For rack installation)	V	1 Set
User manual	V	1 PC

V: standard configuration

3.4 Install the PDU

It is recommended to connect 'Cables for UPS's Input / Output' and 'RJ11 cable' to PDU's side before install PDU to its final location.

1. Remove the cover of terminal blocks and connect 'Cables for UPS's Input/ Output' to terminal blocks refer to the indication on rear panel.

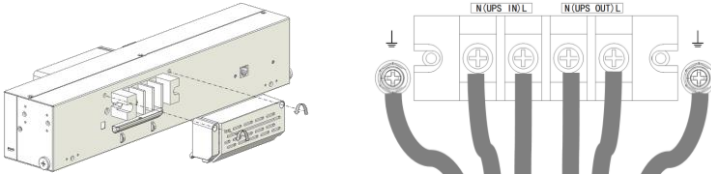

2. Install back the cover of terminal blocks and insert 'RJ11 cable'.

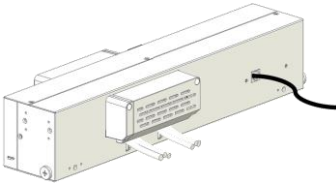

3.4.1 Tower position installing :

Assume that you already purchased our UPS and fix the UPS in tower position.

1. Our UPS provided 2 positions to install the PDU, needed additional space is as below. It is recommended to select 'Left position' as your final installation according to the configuration length of 'Cables for UPS's Input / Output' and 'RJ11 cable'.

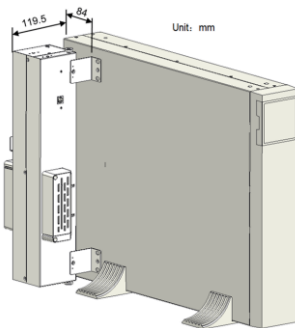

Left position

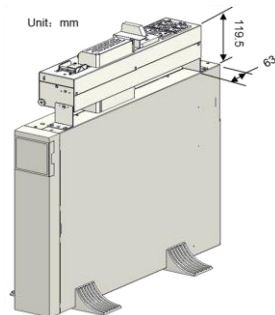

Top position

2. Install 'Ear bracket' to PDU, then assemble PDU to UPS by M4 screws. Below pictures are examples of 'Left position' installation.

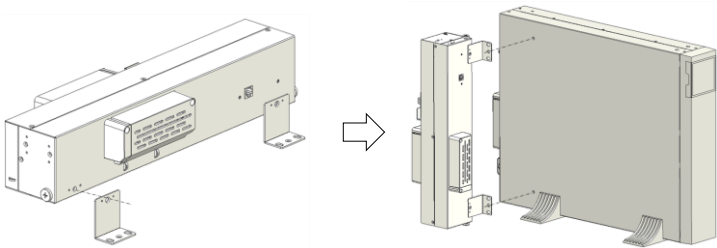

3.4.2 Rack position installing :

This PDU is flexible position installing in a rack cabinet as below.

It is recommended to select 'Position 1' as your final installation according to the configuration length of 'Cables for UPS's Input / Output' and 'RJ11 cable'.

◆ Position 1(Rear of rack)

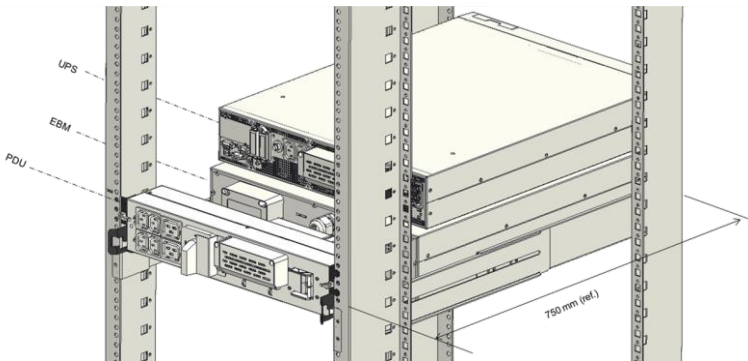

◆ Position 2(Front of rack)

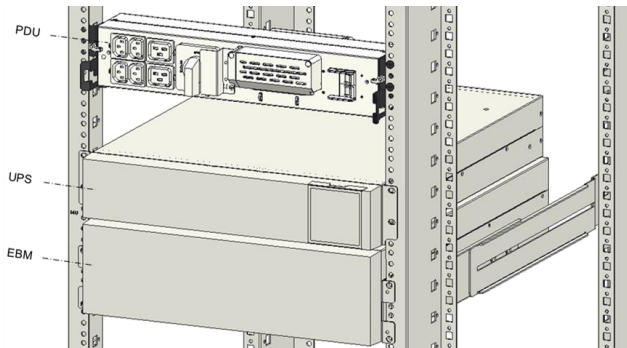

1. Install 'Rail kit' to rack cabinet by M5 screws and washers.

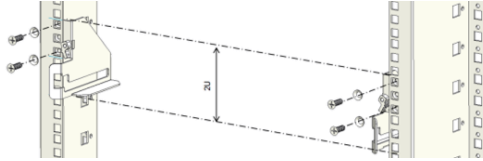

2. Slide PDU into 'rail kit' and make sure lock PDU by the 2 clips.

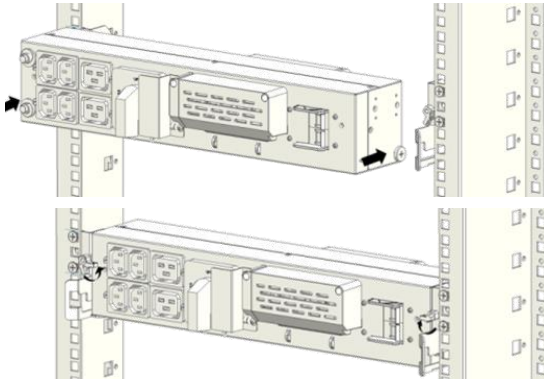

3.4.3 Cables connect to UPS:

1. Connect 'Cables for UPS's Input/ Output' to UPS's terminal blocks refer to below indication.

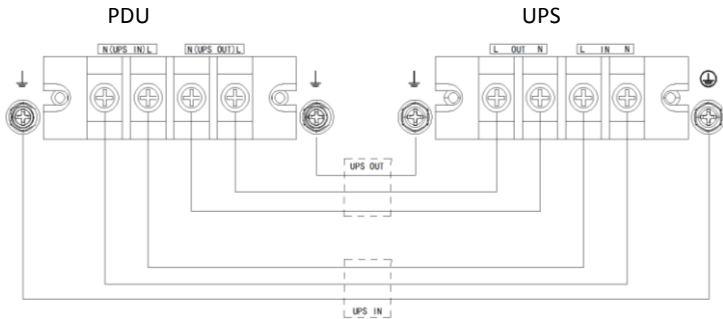

2. Insert 'RJ11 cable' to 'PDU PORT' on the rear of UPS.

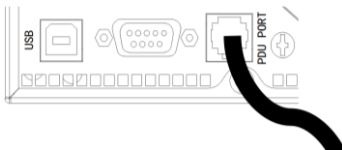

4. AC Power cables connection

Recommended protective devices and cable cross-sections

Recommended upstream protection

Model	PDU (with RT 6K UPS)	PDU (with RT 10K UPS)
Input L, N, G Min conductor cross section	6mm ² (8AWG)	10mm ² (6AWG)
Output L, N, G Min conductor cross section	6mm ² (8AWG)	10mm ² (6AWG)

4.1 AC source to PDU



High leakage current:

Earth connection essential before connecting supply.

Common input/output sources connection



This type of connection must be carried out by qualified electrical personnel

Before carrying out any connection, check that the upstream protection devices (Normal AC source) are open "O" (Off).

1. Remove the cover of terminal block.

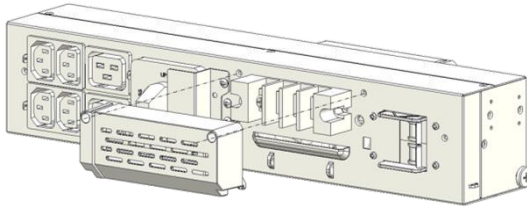

2. Connect the AC cable to terminal blocks refer to the indication on panel.

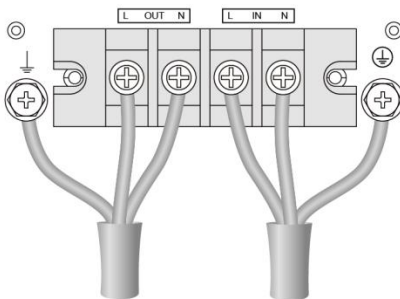

3. Install back the cover of terminal block.

4. You can also select 'Output socket group' as the load connection, this PDU provide 'Cable locker' for reliable connection of the outlet.

5. Service operation

5.1 How to switch system to BYPASS model

1. Remove the 'Maintenance switch cover', the UPS will turn to bypass mode automatically.

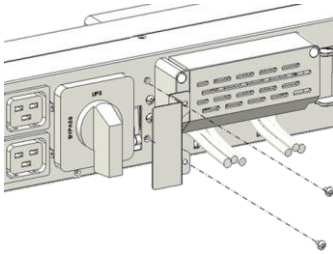

2. Rotate the maintenance switch to "BYPASS" position.

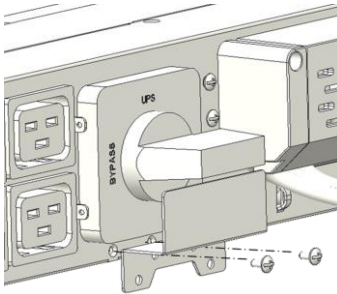

Note: For an unconscious operation, it is recommended to install back the 'Maintenance switch cover' as above to prevent 'BYPASS' switch back to 'UPS'.

3. Turn the PDU's 'Input switch' to 'OFF' position.
4. After these operations, the PDU will power the load directly via maintenance switch.

Note: please make sure the UPS is turned to bypass mode before rotate the maintenance switch to bypass position.

5.2 How to disconnect cables between PDU and UPS

This is to disconnecting 'Cables for UPS's Input / Output' and 'RJ11 cable'.

The pictures as below are examples of 'Rack position' only.

1. Unlock the clips and pull out PDU from its position smoothly, then rotate the PDU as below.

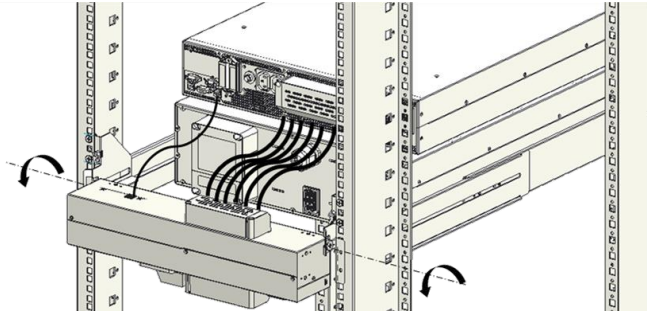

2. Disconnecting 'Cables for UPS's Input / Output' and 'RJ11 cable' as well as other cables connected on UPS.
3. Remove out the UPS for service or replacement.

Note: Don't let the PDU suffer any strong stress during its rotation position.

5.3 How to switch system to NORMAL model

Clarify your UPS is already complete service or replacement installation.

1. Connect 'Cables for UPS's Input/ Output' and 'RJ11 cable' to UPS's terminal ---refer to chapter 3.4.3
2. Turn the PDU's 'Input switch' to 'ON ' position. The UPS will turn to bypass mode.
3. Rotate the maintenance switch to 'UPS' position, install back the 'maintenance switch cover' to its normal position.
4. Press the button on UPS LCD panel, the UPS will turn to line mode.

6. Specifications

1. Power Module model list

Model	Power Ratings
RT MBP	10000VA / 10000W

2. Weights and dimensions

Description	Weights (kg)	Dimensions (mm) W x H x D
RT MBP	2.4	426*84.5(2U)*80

3. Electrical input—refer to the UPS input spec

4. Electrical output—refer to the UPS output spec

Output socket group 1	10A & 16A	Normal output
Output socket group 2	10A & 16A	Programmable output

Outlet socket group 1 and outlet socket group 2 always on if output available (default setting)

Outlet socket group 2 (Programmable) can be set on the LCD or by sending command; it could be set between “always on” and “auto off-on”, and “always on” by default. Once it is set as “auto off-on” that output power will turn off when battery capacity below 50% in battery mode, and outlet socket group 2 will turn on again when charger begins to work.

5. Electrical output connections

Model	Output connection	Cable
6K/6KS	Hardwired	1. Cable for UPS & PDU connection
10K/10KS		2. RJ11 cable

6. Environmental and safety

Certifications	EN 62040-1 IEC/EN 62040-2: Cat. C3 IEC/EN 62040-3 EN 60950-1
EMC (Emissions)*	IEC 61000-3-2 (-3-12) IEC 61000-3-3 (-3-11)
EMC (Immunity)	IEC 61000-4-2, Level 3 IEC 61000-4-3, Level 3 IEC 61000-4-4, Level 4 (also on signal ports) IEC 61000-4-5, Level 4, Criteria B IEC 61000-4-6, Level 3 IEC 61000-4-8, Level 4 IEC 61000-4-11

* for output cable < 10m.

Agency markings	CE
Operating temperature	0~40°C full load 40~50°C derating to 50% 0~35°C IEC socket 16A 35~40°C IEC socket 10A
Storage temperature	-25 to 60°C (5 to 140°F)
Transit temperature	-25 to 55°C (-13 to 130°F)
Relative humidity	0 to 95% no condensing
Operating altitude	Up to 3,000 meters (9,843 ft) above sea level with 10% derating per 1000m
Transit altitude	Up to 10,000 meters (32,808 ft) above sea level

